

QW Series

Wide Rail

(1) Non-interchangeable type

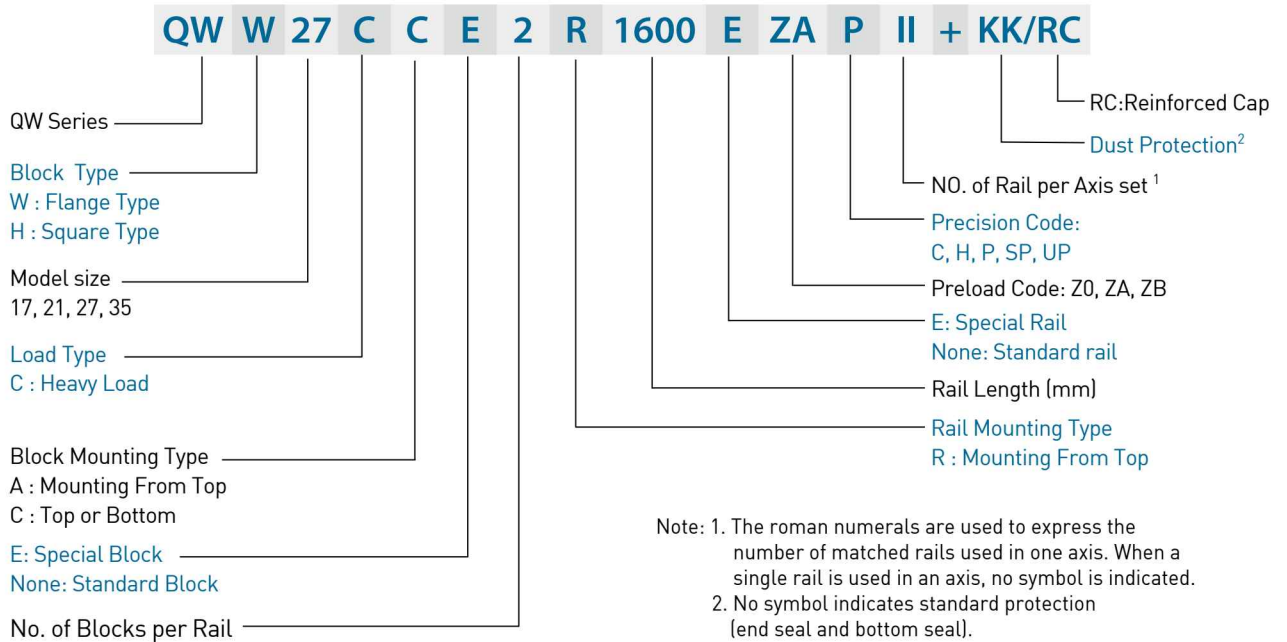

Note: 1. The roman numerals are used to express the number of matched rails used in one axis. When a single rail is used in an axis, no symbol is indicated.
2. No symbol indicates standard protection (end seal and bottom seal).
ZZ : End seal, bottom seal and scraper
KK: Double seals, bottom seal and scraper.
DD: Double seals and bottom seal

(2) Interchangeable type

○ Model Number of QW Block

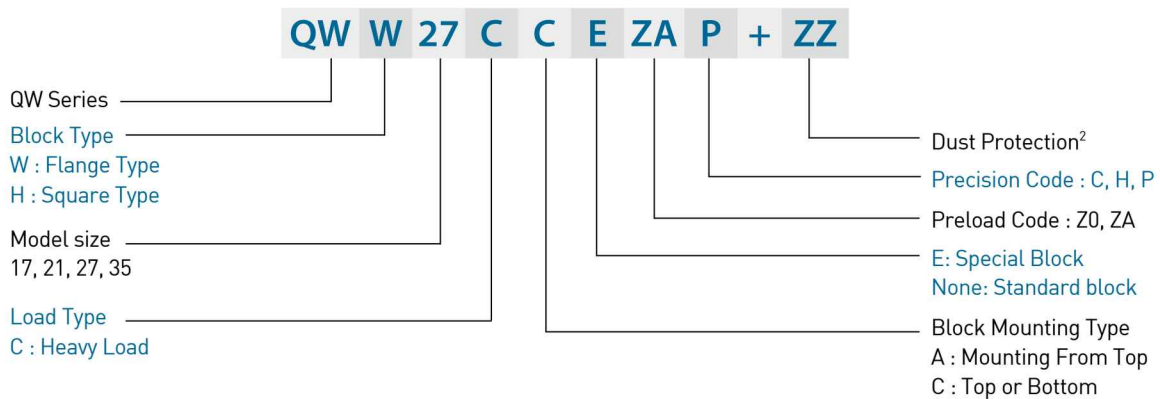

○ Model Number of QW Rail (QW and WE share the identical rails)

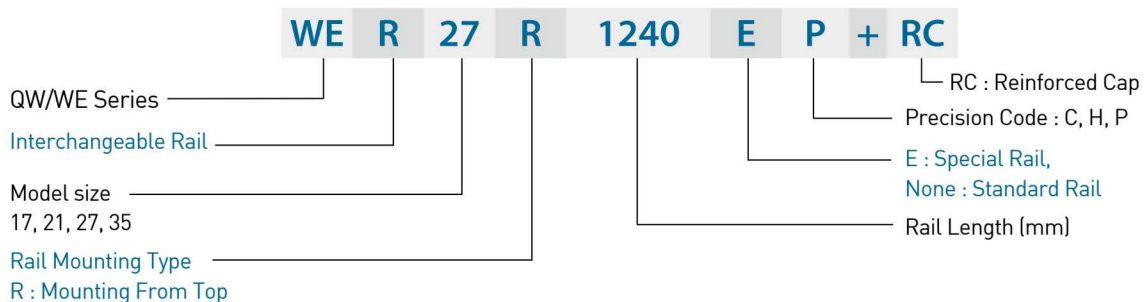

2-7-4 Accuracy

The accuracy of the QW series can be classified into 5 classes: normal(C), high(H), precision(P), super precision(SP), and ultra precision(UP). Choose the class by referencing the accuracy of selected equipment.

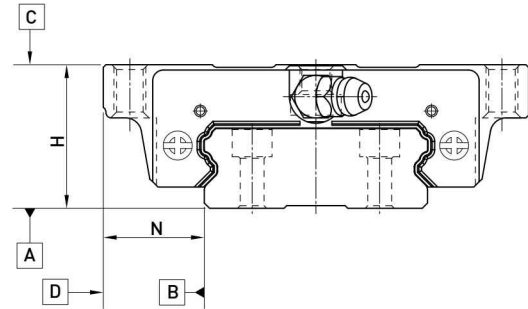

(1) Accuracy of non-interchangeable guideways

Table 2-7-1 Accuracy Standards

Unit: mm

Type	QW - 17, 21					QW - 27, 35				
	Normal (C)	High (H)	Precision (P)	Super Precision (SP)	Ultra Precision (UP)	Normal (C)	High (H)	Precision (P)	Super Precision (SP)	Ultra Precision (UP)
Dimensional tolerance of height H	± 0.1	± 0.03	0 - 0.03	0 - 0.015	0 - 0.008	± 0.1	± 0.04	0 - 0.04	0 - 0.02	0 - 0.01
Dimensional tolerance of width N	± 0.1	± 0.03	0 - 0.03	0 - 0.015	0 - 0.008	± 0.1	± 0.04	0 - 0.04	0 - 0.02	0 - 0.01
Variation of height H	0.02	0.01	0.006	0.004	0.003	0.02	0.015	0.007	0.005	0.003
Variation of width N	0.02	0.01	0.006	0.004	0.003	0.03	0.015	0.007	0.005	0.003
Running parallelism of block surface C to surface A	See Table 2-7-3									
Running parallelism of block surface D to surface B	See Table 2-7-3									

(2) Accuracy of interchangeable guideways

Table 2-7-2 Accuracy Standards

Unit: mm

Item	QW - 17, 21			QW - 27, 35		
	Normal (C)	High (H)	Precision (P)	Normal (C)	High (H)	Precision (P)
Dimensional tolerance of height H	± 0.1	± 0.03	± 0.015	± 0.1	± 0.04	± 0.02
Dimensional tolerance of width N	± 0.1	± 0.03	± 0.015	± 0.1	± 0.04	± 0.02
Variation of height H	0.02	0.01	0.006	0.02	0.015	0.007
Variation of width N	0.02	0.01	0.006	0.03	0.015	0.007
Running parallelism of block surface C to surface A	See Table 2-7-3					
Running parallelism of block surface D to surface B	See Table 2-7-3					

QW Series

Wide Rail

(3) Accuracy of running parallelism

Table 2-7-3 Accuracy of Running Parallelism

Rail Length (mm)	Accuracy (μm)				
	C	H	P	SP	UP
~ 100	12	7	3	2	2
100 ~ 200	14	9	4	2	2
200 ~ 300	15	10	5	3	2
300 ~ 500	17	12	6	3	2
500 ~ 700	20	13	7	4	2
700 ~ 900	22	15	8	5	3
900 ~ 1,100	24	16	9	6	3
1,100 ~ 1,500	26	18	11	7	4
1,500 ~ 1,900	28	20	13	8	4
1,900 ~ 2,500	31	22	15	10	5
2,500 ~ 3,100	33	25	18	11	6
3,100 ~ 3,600	36	27	20	14	7
3,600 ~ 4,000	37	28	21	15	7

2-7-5 Preload

(1) Definition

A preload can be applied to each guideway. Generally, a linear motion guideway has a negative clearance between the groove and balls in order to improve stiffness and maintain high precision. The figure shows that adding a preload can improve stiffness of the linear guideway.

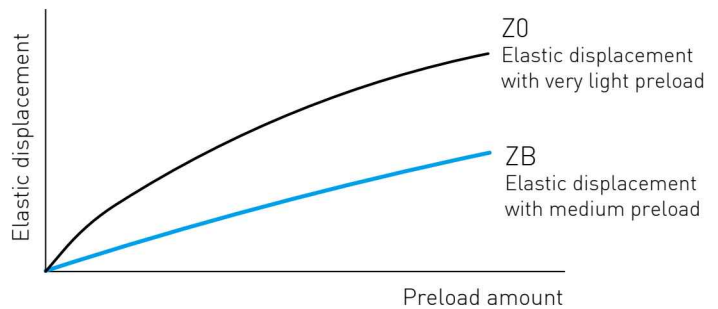

(2) Preload classes

HIWIN offers three standard preloads for various applications and conditions.

Table 2-7-4 Preload Classes

Class	Code	Preload	Condition
Very Light Preload	Z0	0~ 0.02C	Certain load direction, low impact, low precision requirement
Light Preload	ZA	0.03C~0.05C	low load and high precision requirement
Medium Preload	ZB	0.06C~ 0.08C	High rigidity requirement, with vibration and impact

Class	Interchangeable Guideway	Non-Interchangeable Guideway
Preload classes	Z0, ZA	Z0, ZA, ZB

Note: The "C" in the preload column denotes basic dynamic load rating.

2-7-6 Dust Protection Equipment

(1) Codes of equipment

If the following equipment is needed, please indicate the code followed by the model number.

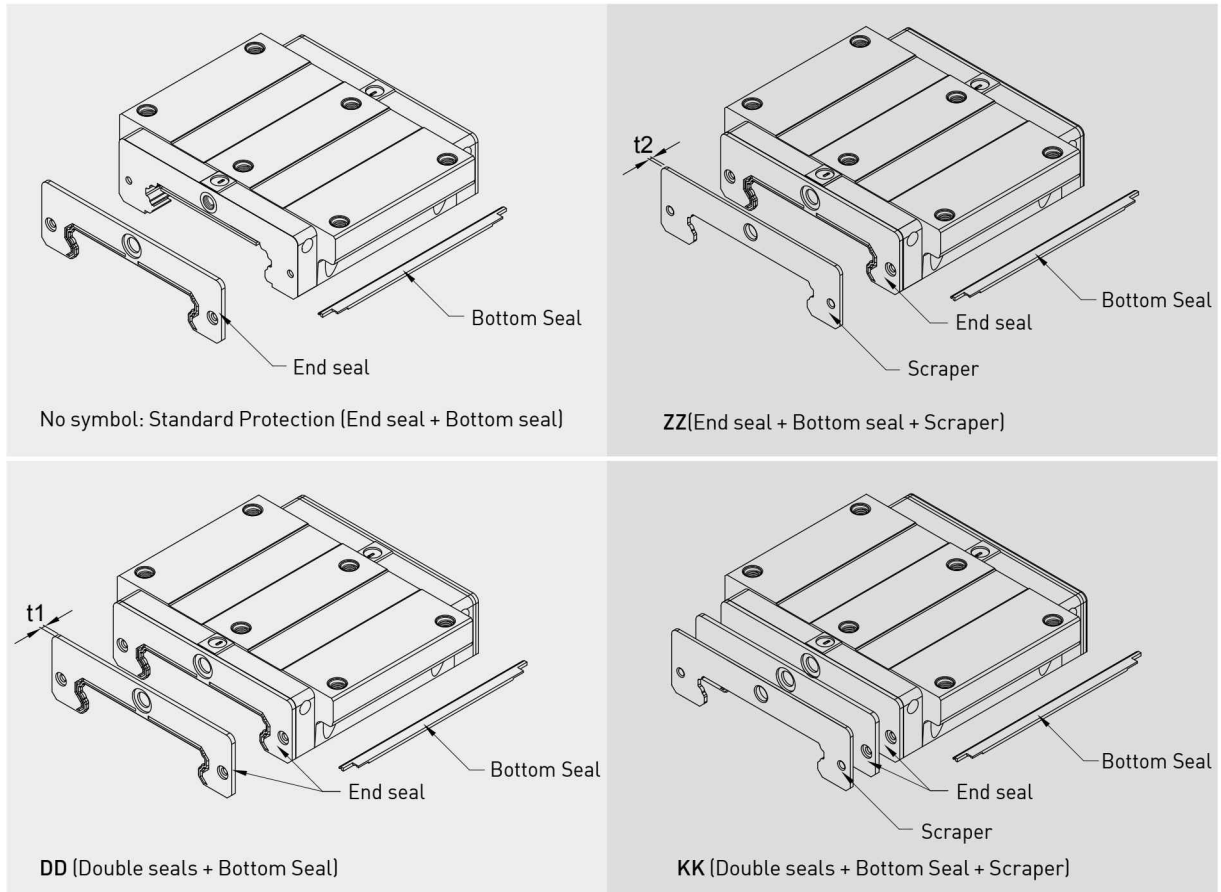

(2) End seal and bottom seal

Protects against contaminants entering the block. Reduces potential for groove damage resulting in a reduction of life ratings.

(3) Double seals

Removes foreign matter from the rail preventing contaminants from entering the block.

Table 2-7-5 Dimensions of end seal

Size	Thickness (t1) (mm)	Size	Thickness (t1) (mm)
QW17	1.6	QW27	2
QW21	2	QW35	2

QW Series

Wide Rail

(4) Scraper

Clears larger contaminants, such as weld spatter and metal cuttings, from the rail. Metal scraper protects end seals from excessive damage.

Table 2-7-6 Dimensions of Scraper

Size	Thickness (t2) (mm)	Size	Thickness (t2) (mm)
QW17	1	QW27	1
QW21	1	QW35	1.5

(5) Bolt caps for rail mounting holes

Rail mounting hole caps prevent foreign matter from accumulating in the mounting holes. Caps are included with the rail package.



Table 2-7-7 Dimensions of Bolt Caps for Rail Mounting Holes

Rail size	Bolt size	Diameter(D) (mm)	Thickness(H) (mm)
QWR17R	M4	7.65	1.1
QWR21R	M4	7.65	1.1
QWR27R	M4	7.65	1.1
QWR35R	M6	11.20	2.5

(6) Dimensions of block equipped with the dustproof parts

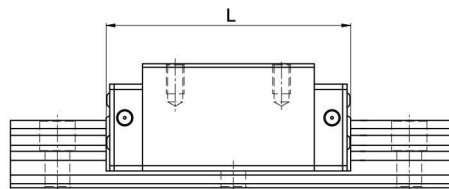

Table 2-7-8 Overall block length

unit: mm

Size	Overall block length (L)			
	SS	ZZ	DD	KK
QW17C	51.0 (53.0)	53.0 (56.0)	54.2 (56.2)	56.2 (59.2)
QW21C	59.0 (63.0)	61.0 (67.0)	63.0 (67.0)	65.0 (71.0)
QW27C	73.2 (77.2)	75.2 (81.2)	77.2 (81.2)	79.2 (85.2)
QW35C	107.0 (111.0)	110.0 (116.0)	111.0 (115.0)	114.0 (120.0)

Note : The marking of "[]" denotes the maximum block length with screws, lips of end seals, etc.

2-7-7 Friction

The maximum value of resistance per end seal are as shown in the table.

Table 2-7-9 Seal Resistance

Size	Resistance N (kgf)	Size	Resistance N (kgf)
QW17	1.18 (0.12)	QW27	2.94 (0.3)
QW21	1.96 (0.2)	QW35	3.92 (0.4)

Note: 1kgf=9.81N

2-7-8 Mounting Surface Accuracy Tolerance

Because of the circular-arc contact design, the QW linear guideway can withstand surface-error installation and deliver smooth linear motion. When the mounting surface meets the accuracy requirements of the installation, the high accuracy and rigidity of the guideway will be obtained without any difficulty. For faster installation and smoother movement, HIWIN offers a preload with normal clearance because of its ability to absorb higher deviations in mounting surface inaccuracies.

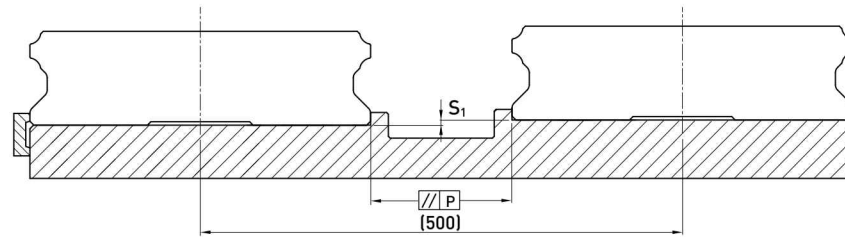

Table 2-7-10 Max. Parallelism Tolerance (P)

unit: μm

Size	Preload classes			Size	Preload classes		
	Z0	ZA	ZB		Z0	ZA	ZB
QW17	20	15	-	QW27	25	20	-
QW21	25	18	-	QW35	30	22	20

Table 2-7-11 Max. Tolerance of Reference Surface Height (S₁)

unit: μm

Size	Preload classes			Size	Preload classes		
	Z0	ZA	ZB		Z0	ZA	ZB
QW17	65	20	-	QW27	130	85	-
QW21	130	85	-	QW35	130	85	70

2-7-9 Cautions for Installation

(1) Shoulder heights and chamfers

Improper shoulder heights and chamfers of mounting surfaces will cause deviations in accuracy and rail or block interference with the chamfered part.

When recommended shoulder heights and chamfers are used, problems with installation accuracy should be eliminated.

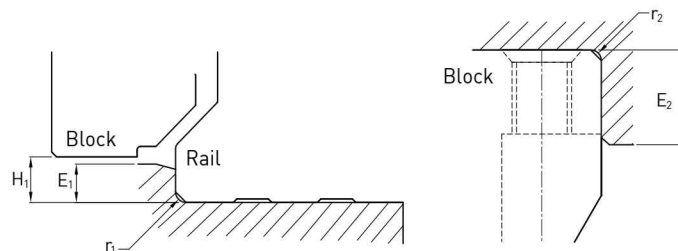

Table 2-7-12 Shoulder Heights and Chamfers

unit: mm

Size	Max. radius of fillets r_1 (mm)	Max. radius of fillets r_2 (mm)	Shoulder height of the rail E_1 (mm)	Shoulder height of the block E_2 (mm)	Clearance under block H_1 (mm)
QW17	0.4	0.4	2.0	4.0	2.5
QW21	0.4	0.4	2.5	5.0	3.0
QW27	0.5	0.4	2.5	7.0	4.0
QW35	0.5	0.5	2.5	10.0	4.0

QW Series

Wide Rail

(2) Tightening Torque of Bolts for Installation

Improperly tightened mounting bolts will seriously affect the accuracy of linear guide installations. The following tightening torques for different sizes of bolts are recommended.

Table 2-7-13 Tightening Torque

Size	Bolt size	Torque N-cm(kgf-cm)		
		Iron	Casting	Aluminum
QW17	M4×0.7P×12L	392 (40)	274 (28)	206 (21)
QW21	M4×0.7P×12L	392 (40)	274 (28)	206 (21)
QW27	M4×0.7P×16L	392 (40)	274 (28)	206 (21)
QW35	M6×1P×20L	1373 (140)	921 (94)	686 (70)

Note: 1 kgf = 9.81 N

2-7-10 Standard and Maximum Lengths of Rail

HIWIN offers a number of standard rail lengths. Standard rail lengths feature end mounting hole placements set to predetermined values (E). For non-standard rail lengths, be sure to specify the E-value to be no greater than 1/2 the pitch (P) dimension. An E-value greater than this will result in unstable rail ends.

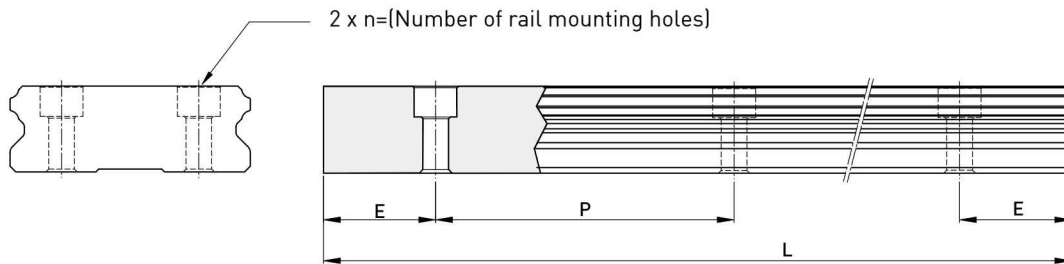

$$L = (n - 1) \times P + 2 \times E \quad \text{Eq.2.3}$$

L : Total length of rail (mm)

n : Number of mounting holes

P : Distance between any two holes (mm)

E : Distance from the center of the last hole to the edge (mm)

Table 2-7-14 Rail Standard Length and Max. Length

unit: mm

Item	QWR17	QWR21	QWR27	QWR35
Standard Length L(n)	110 (3)	130 (3)	220 (4)	280 (4)
	190 (5)	230 (5)	280 (5)	440 (6)
	310 (8)	380 (8)	340 (6)	600 (8)
	390 (10)	480 (10)	460 (8)	760 (10)
	470 (12)	580 (12)	640 (11)	1000 (13)
	550 (14)	780 (16)	820 (14)	1,640 (21)
	-	-	1,000 (17)	2,040 (26)
	-	-	1,240 (21)	2,520 (32)
Pitch (P)	40	50	60	80
Distance to End (E _s)	15	15	20	20
Max. Standard Length	4,000 (100)	4,000 (80)	4,000 (67)	3,960 (50)
Max. Length	4,000	4,000	4,000	4,000

Note : 1. Tolerance of E value for standard rail is 0.5--0.5 mm. Tolerance of E value for jointed rail is 0--0.3 mm.
 2. Maximum standard length means the max. rail length with standard E value on both sides.
 3. If different E value is needed, please contact HIWIN.

2-7-11 Dimensions for HIWIN QW Series

(1) QWH-CA

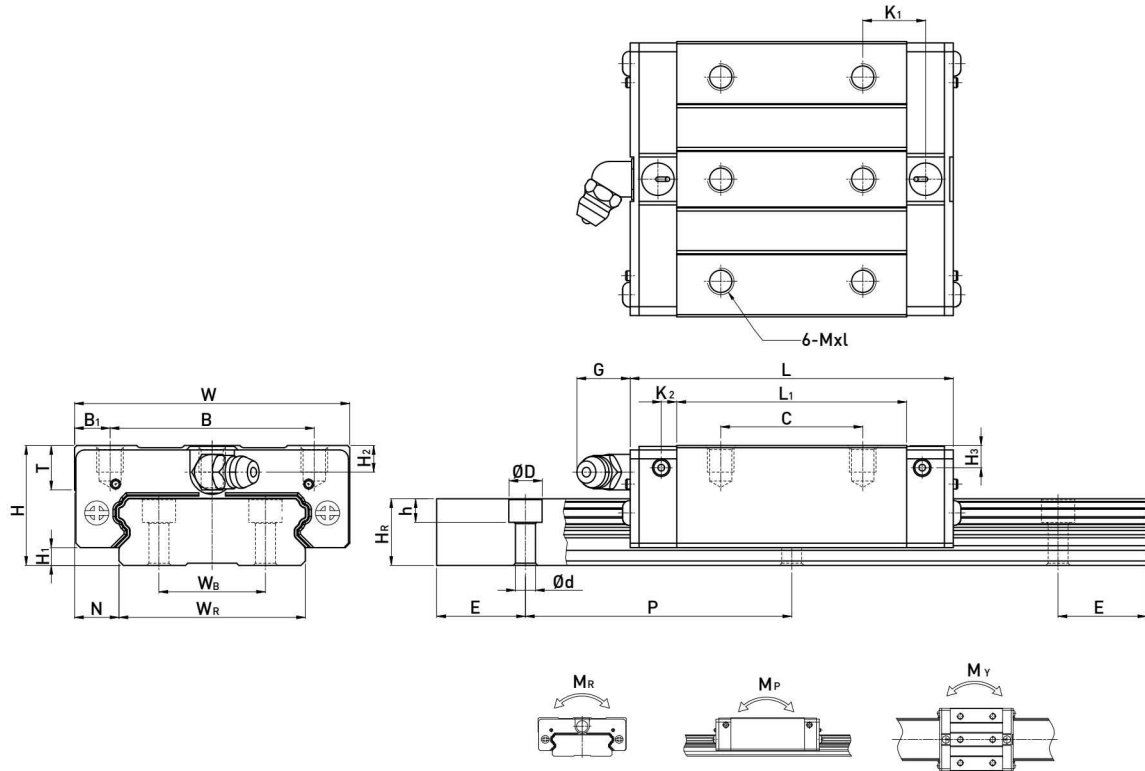

Model No.	Dimensions of Assembly (mm)			Dimensions of Block (mm)											Dimensions of Rail (mm)					Mounting Bolt for Rail (mm)	Basic Dynamic Load Rating C (kN)	Basic Static Load Rating C ₀ (kN)	Static Rated Moment			Weight						
	H	H ₁	N	W	B	B ₁	C	L ₁	L	K ₁	K ₂	G	Mxl	T	H ₂	H ₃	W _R	W _B	H _R				D	h	d	P	E	M _R	M _P	M _Y	Block	Rail
	kgf	mm	mm	mm	mm	mm	mm	mm	mm	mm	mm	mm	mm	mm	mm	mm	mm	mm	mm				mm	mm	mm	mm	mm	mm	kN-m	kN-m	kN-m	kg
QWH17CA	17	2.5	8.5	50	29	10.5	15	38	51	13.95	2.45	4.9	M4x5	6	4	2.5	33	18	9.3	7.5	5.3	4.5	40	15	M4x12	7.32	9.1	0.14	0.055	0.055	0.12	2.2
QWH21CA	21	3	8.5	54	31	11.5	19	41.7	59	14.68	3.3	12	M5x6	8	4.5	4.2	37	22	11	7.5	5.3	4.5	50	15	M4x12	8.1	12.1	0.21	0.08	0.08	0.2	3
QWH27CA	27	4	10	62	46	8	32	56.6	73.2	15.45	3.15	12	M6x6	10	6	5	42	24	15	7.5	5.3	4.5	60	20	M4x16	16	22.2	0.42	0.2	0.2	0.35	4.7
QWH35CA	35	4	15.5	100	76	12	50	83	107	21.5	5	12	M8x8	13	8	6.5	69	40	19	11	9	7	80	20	M6x20	36.8	49.2	1.51	0.65	0.65	1.1	9.7

Note : 1 kgf = 9.81 N

QW Series

Wide Rail

(2) QWW-CC

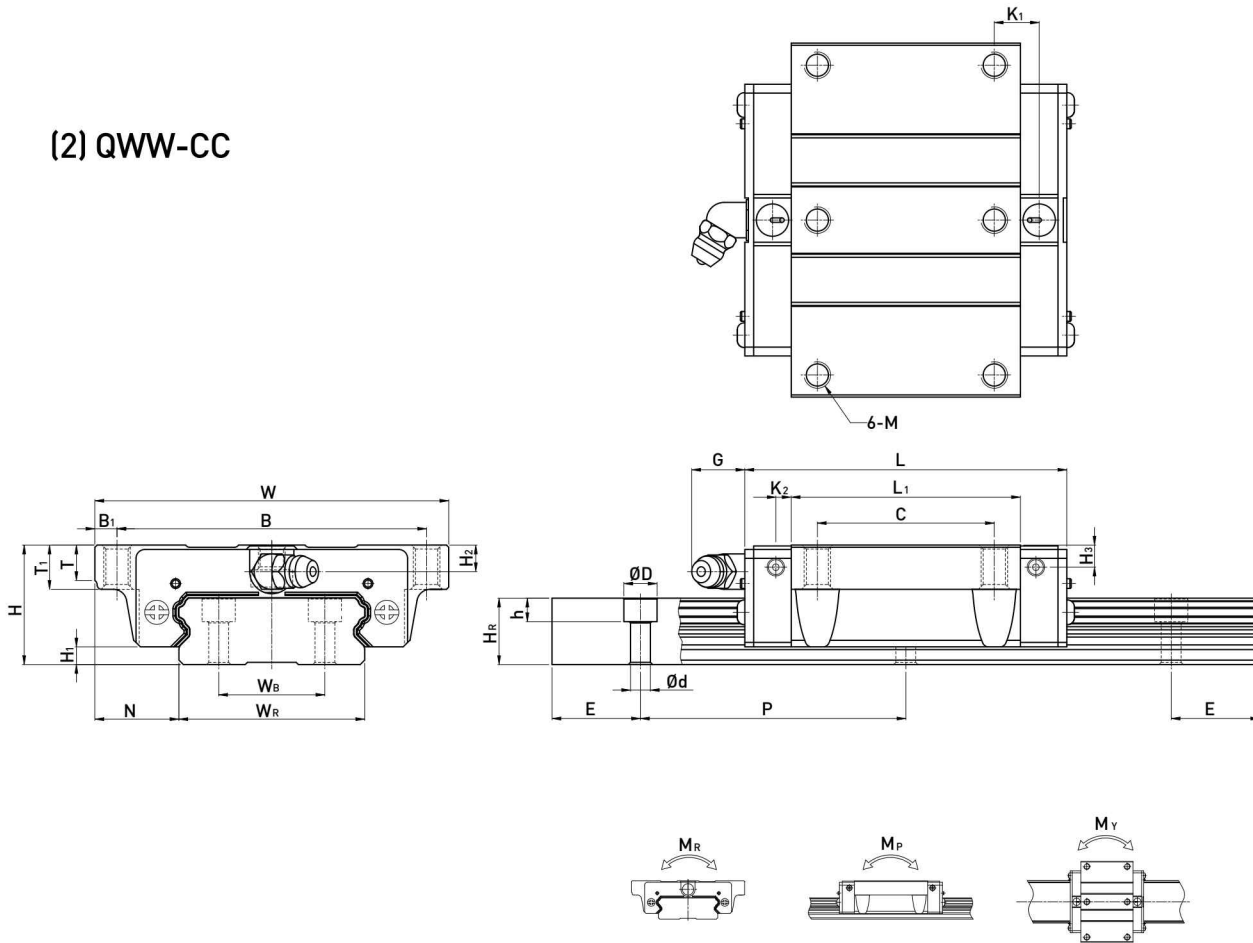

Model No.	Dimensions of Assembly (mm)			Dimensions of Block (mm)													Dimensions of Rail (mm)					Mounting Bolt for Rail (mm)	Basic Dynamic Load Rating C(kN)	Basic Static Load Rating C ₀ (kN)	Static Rated Moment			Weight					
	H	H ₁	N	W	B	B ₁	C	L ₁	L	K ₁	K ₂	G	M	T	T ₁	H ₂	H ₃	W _R	W _B	H _R	D				h	d	P	E	M _R	M _P	M _Y	Block	Rail
	kg	kg	kg	kg	kg	kg	kg	kg	kg	kg	kg	kg	kg	kg	kg	kg	kg	kg	kg	kg	kg				kg	kg	kg	kg	kg	kg	kg	kg	kg
QWW17CC	17	2.5	13.5	60	53	3.5	26	38	51	8.45	2.45	4.9	M4	6	5.1	4	2.5	33	18	9.3	7.5	5.3	4.5	40	15	M4x12	7.32	9.1	0.14	0.055	0.055	0.13	2.2
QWW21CC	21	3	15.5	68	60	4	29	41.7	59	9.68	3.3	12	M5	7.3	8	4.5	4.2	37	22	11	7.5	5.3	4.5	50	15	M4x12	8.1	12.1	0.21	0.08	0.08	0.23	3
QWW27CC	27	4	19	80	70	5	40	56.6	73.2	11.45	3.15	12	M6	8	10	6	5	42	24	15	7.5	5.3	4.5	60	20	M4x16	16	22.2	0.42	0.2	0.2	0.43	4.7
QWW35CC	35	4	25.5	120	107	6.5	60	83	107	16.50	5	12	M8	11.2	14	8	6.5	69	40	19	11	9	7	80	20	M6x20	36.8	49.2	1.51	0.65	0.65	1.26	9.7

Note : 1 kgf = 9.81 N